

Martin SPROCKET NOMENCLATURE

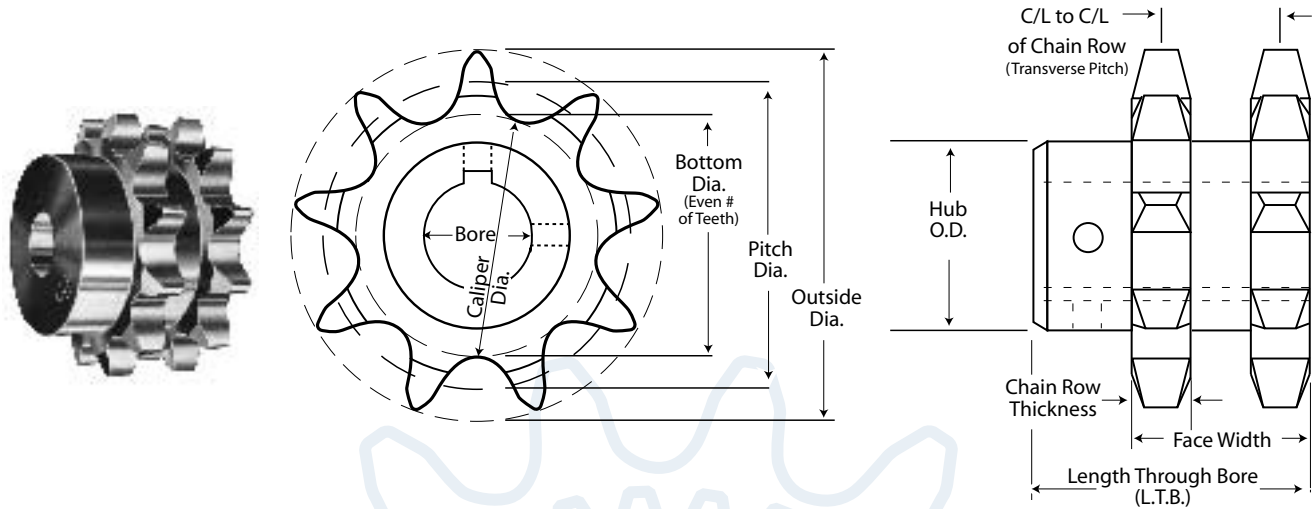

D 160 B 16 H 2 1/4 KWSS

of Strands

Blank	Single
D	Double
E	Triple
F	Quadruple
DS	Double Single

Chain Pitch (measured in eighths)

25 = 2/8 = 1/4"	100 = 10/8 = 1-1/4"
35 = 3/8 = 3/8"	120 = 12/8 = 1-1/2"
40 = 4/8 = 1/2"	140 = 14/8 = 1-3/4"
41 = 4/8 = 1/2"	160 = 16/8 = 2"
50 = 5/8 = 5/8"	180 = 18/8 = 2-1/4"
60 = 6/8 = 3/4"	200 = 20/8 = 2-1/2"
80 = 8/8 = 1"	240 = 24/8 = 3"

Sprocket Type

A	Plate Only
B	Hub One Side
C	Hub Both Sides
D	Detachable Hubs
JA, SH, ...	- QD
BTB	- Taper Bore
H, P, Q, ...	- MST

of Teeth

Special Instructions
H - Hardened Teeth
SS - Stainless Steel

Bore Size

Bore Options

KW	Keyway
SS	One setscrew over keyway
2SS	Two setscrews, (one over keyway and the second at 90 degrees.)

TYPES OF SPROCKETS

